

Installation and

Operations Manual

for the

Post, Wall, & Cabinet Mounted Delivery Systems

(229-032)

P/N 70-874 (AS-1 Hygiene Delivery - Post)

P/N 70-875 (AS-1 Delivery - Post)

P/N 70-882 (AS-2 Delivery - Post)

P/N 70-935 (Engle 300 Delivery - Post)

P/N 70-877 (AS-1 Hygiene Delivery - Wall)

P/N 70-876 (AS-1 Delivery - Wall)

P/N 70-883 (AS-2 Delivery - Wall)

P/N 70-936 (Engle 300 Delivery - Wall)

P/N 70-876S (AS-1 Delivery - Cabinet)

P/N 70-883S (AS-2 Delivery - Cabinet)

P/N 70-936S (Engle 300 Delivery - Cabinet)

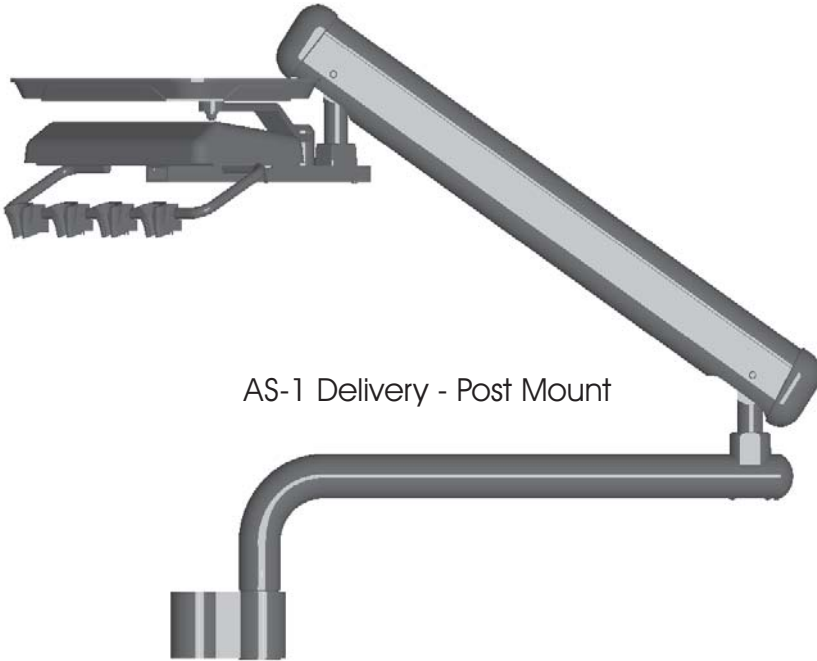

AS-1 Delivery - Post Mount



AS-2 Delivery - Wall Mount



Engle 300 Delivery - Cabinet Mount





P.O. Box 725 · 4115 24th Avenue Suite A · Forest Grove, Oregon 97116, USA
www.engledental.com

INSTALLATION AND OPERATION MANUAL

Customer Service:

7:00 A.M. to 4:30 P.M. (Pacific Time)
Phone: 800-547-1906
Fax: 503-357-7286
E-mail: info@engledental.com

Technical Support:

7:00 A.M. to 4:00 P.M. (Pacific Time)
Phone: 800-547-1906
Fax: 503-357-7286
E-mail: support@engledental.com

Warranty

Products sold to and installed by authorized Engle Dental Systems dealers are guaranteed against defects in materials and workmanship for a period of five (5) years after date of purchase. Engle 300 dental chair Electronic Positioning Components have a Limited Warranty of ten (10) years after date of purchase. Upholstery is guaranteed for one (1) year after date of purchase. All hand-piece illumination systems are guaranteed for six (6) months after date of purchase. This warranty does not cover light bulbs of any kind.

Faulty parts as determined by dealer service representative, will be repaired or replaced; no claim for labor or consequential damages will be allowed. Invoices for replacement parts may be subject to adjustment after the manufacturer has inspected the alleged defective parts.

The warranty does not cover normal wear, stains, cuts, or scratches of upholstery surface finishes, or parts sold to O.E.M. customers.

This warranty does not cover damage resulting from the use of cleaning, disinfecting, or sterilization chemicals and processes.

The warranty does not cover damage from improper installation or maintenance, accident, misuse, or accidents incurred in shipping and handling.

In the event of shipping damage, the purchaser must initiate all claims against the freight carrier in writing within twenty-four (24) hours after the damaged items are received. The claim is the responsibility of the customer.

PRODUCT MODIFICATIONS

Engle Dental Systems continually works to better our products. We reserve the right to make modifications without notice or obligation to modify previously manufactured products.

CLEANING AND DISINFECTING ENGLE EQUIPMENT

Infection control in the dental office continues to be a high priority for our customers and end users. O.S.H.A., the A.D.A., and the C.D.C. are also involved in this complex issue.

We will not attempt to specify the required intervals for disinfection nor can we state what is the overall best surface disinfectant. Please refer to the Infection Control Recommendations published by the American Dental Association for further reference.

Barrier Technique

ENGLE strongly advocates the barrier technique be used whenever possible to preserve the finish and appearance of the equipment. Wherever possible disposable barriers should be used and changed between patients. The barrier technique will ensure maximum long term durability of the surfaces and finishes of equipment.

Chemical Disinfection

Regardless of the chemical disinfectant used it is imperative that the equipment be thoroughly washed with mild soap and warm water at least once per day. This wash down will minimize the harmful effects of chemical disinfectant residues being allowed to accumulate on the equipment.

When using a chemical disinfectant, always pay strict attention to the manufacturer's application directions of the disinfectant. When using a concentrated disinfectant, always pay strict attention to the manufacturer's diluting directions of the disinfectant. *"Disinfectant solutions that are relatively harmless to surfaces at their recommended strengths can be corrosive at a higher/purer concentrate."*

Unacceptable Disinfectants

These disinfectants **WILL HARM** the surface finishes of ENGLE equipment and are **NOT RECOMMENDED**.
USE OF THESE PRODUCTS WILL VOID YOUR WARRANTY.

CHEMICAL COMPOSITION	TRADE NAMES
Strong Phenols/Phenol-Alcohol Combinations	Lysol, Lysol 2, Lysol Professional Coe Foam, Coe Spray Pump, Vitaphone, Omni II
Sodium Hypochlorite/Household Bleach	Clorox, Ajax, Purex
Alcohol	
Household Cleaners	

Conditionally Acceptable Disinfectants*

These disinfectants have been found to be the LEAST HARMFUL to the equipment surfaces.
None of these products are recommended for chair upholstery. Use the barrier technique.

CHEMICAL COMPOSITION	TRADE NAMES
Iodophors**	Biocide, Aseptic-IDC Wescodyne, SD5, Promedyne, Ido-Five
Mild Phenols	Procide ES, Asepti-Steryl Aerosol
Glutaraldehyde/Phenol sprays	Sterall Spray, Coldspor
Synergized Super Quat	Dis-cide, Cavicide, Kleenaseptic
Phenol/Water Sprays	Top-Cide, Sporidicin Pump Spray, Birex se

* ENGLE DENTAL SYSTEMS makes no representation as to the disinfectant efficacy of these products. We make no warranty, expressed or implied, that these disinfectants will not damage the surface finishes. Damage and discoloration of the surface finishes is not covered under the warranty.

** Iodophor based disinfectants will cause yellow staining on many surfaces. Regular washing with soap and water will minimize this staining. Iodophor neutralizers such as Promedyne are also available.

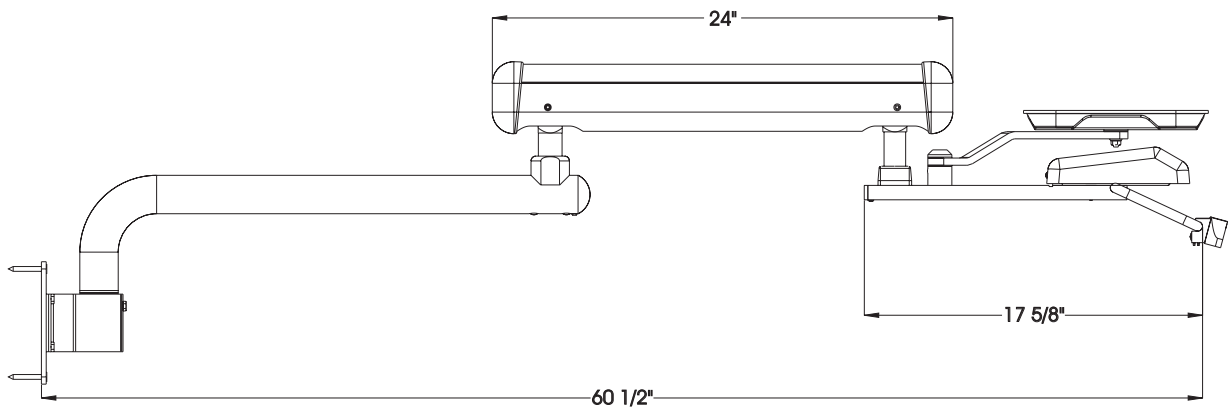
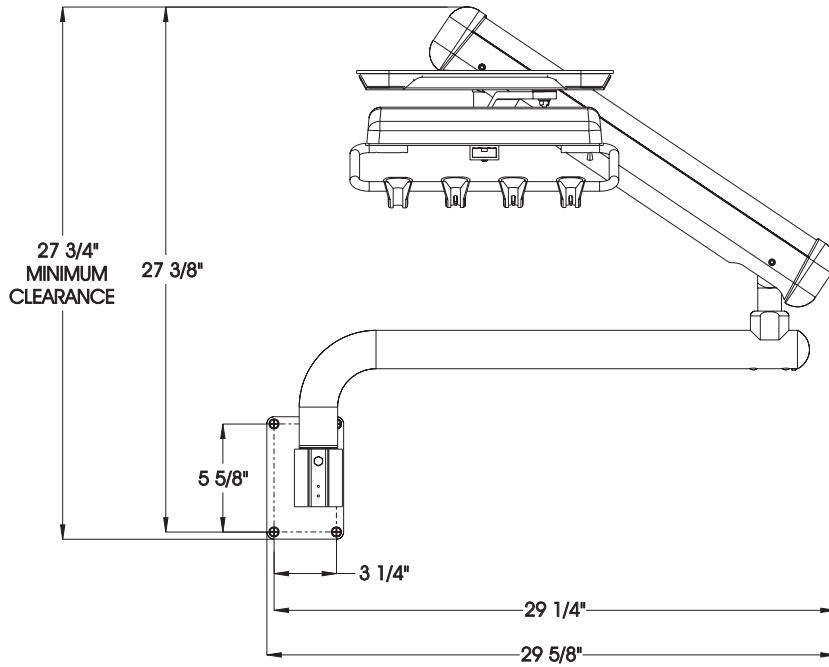

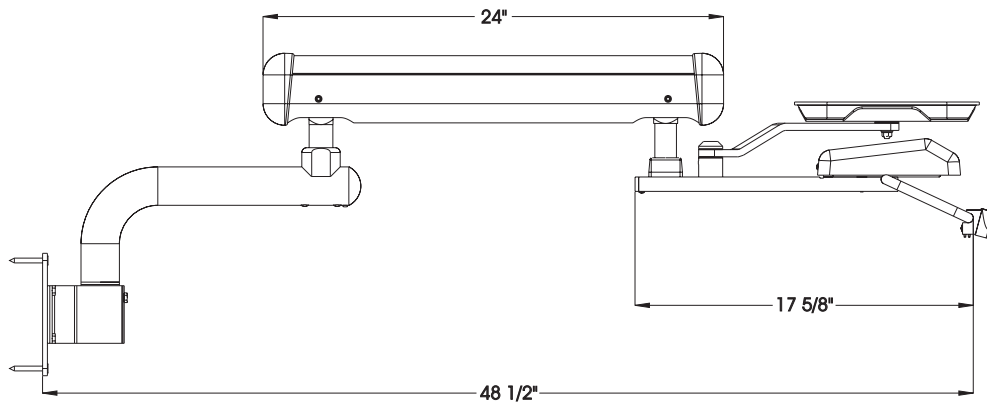
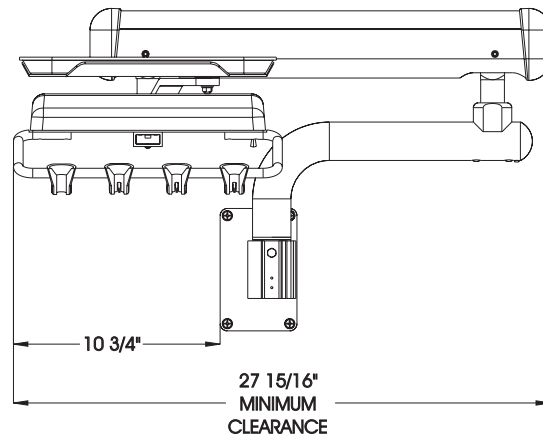
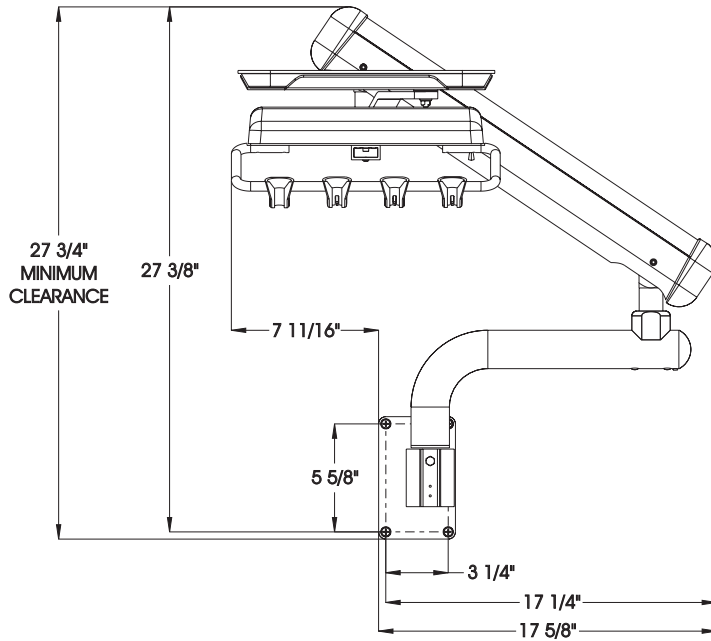

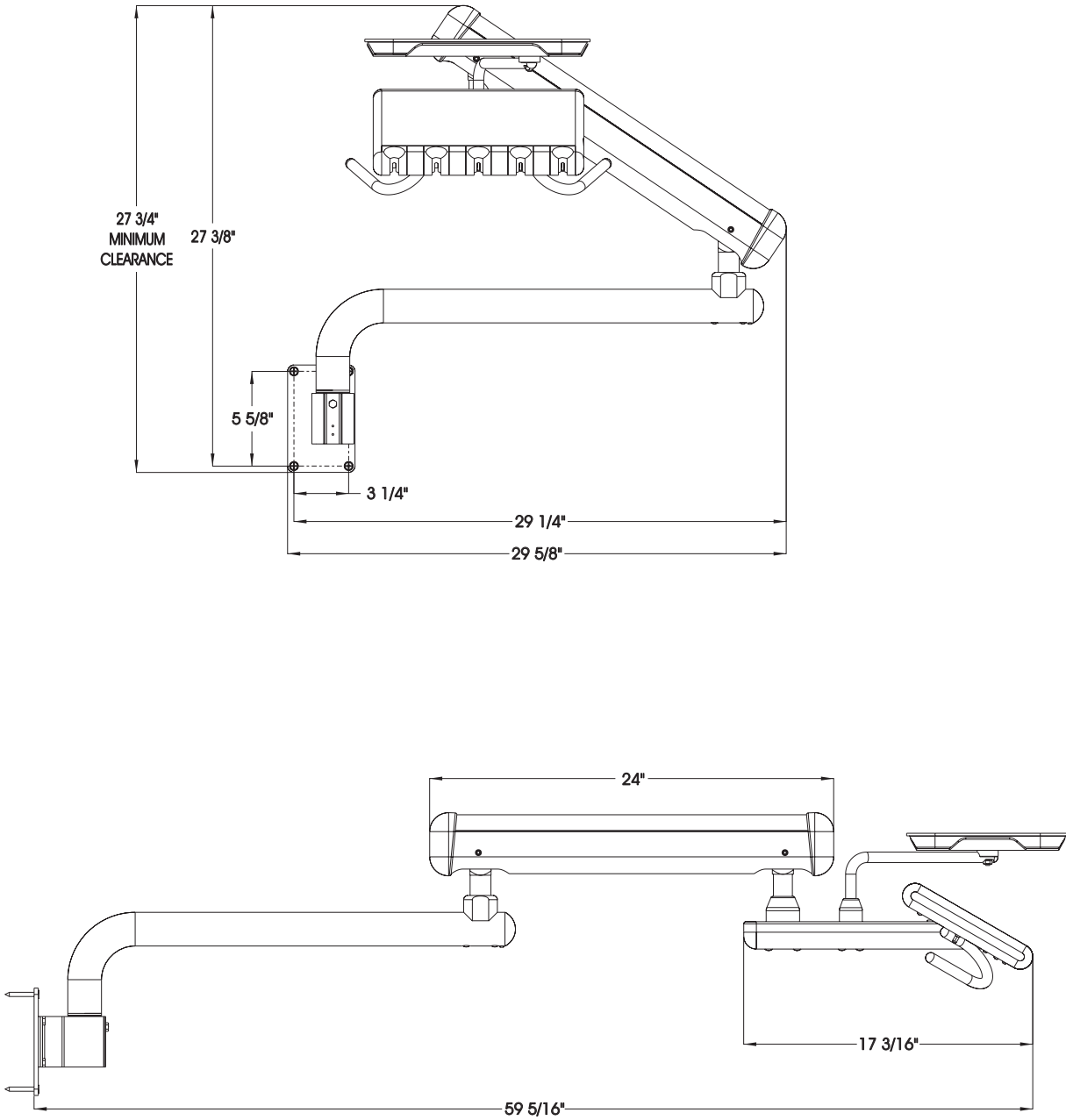

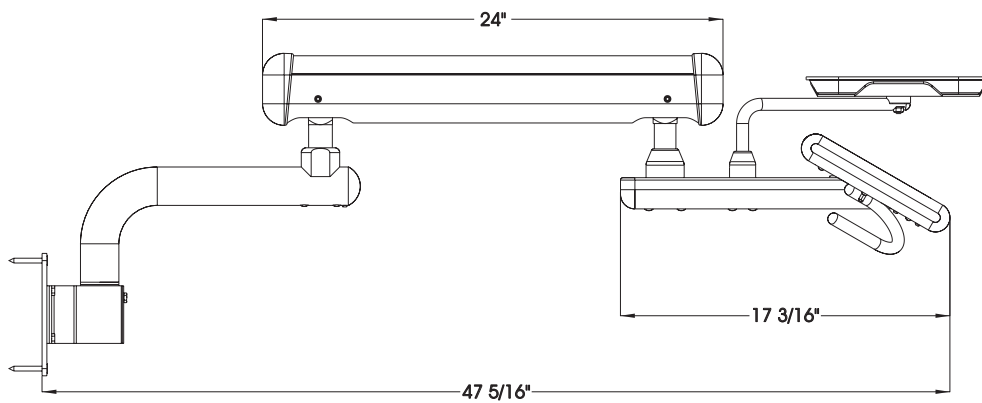
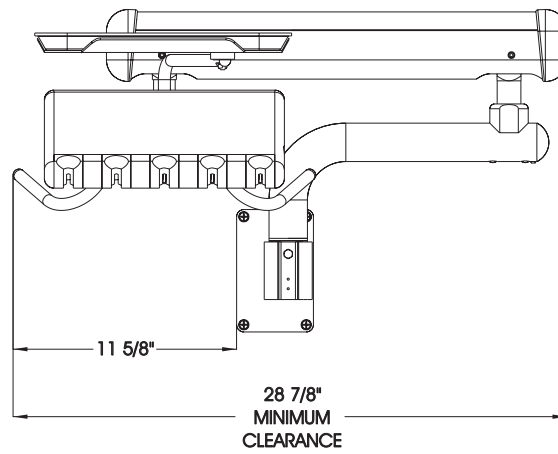
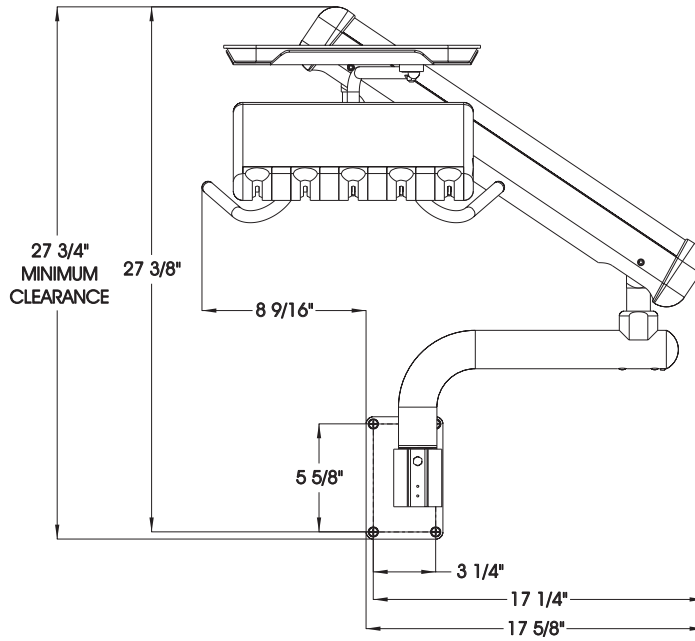

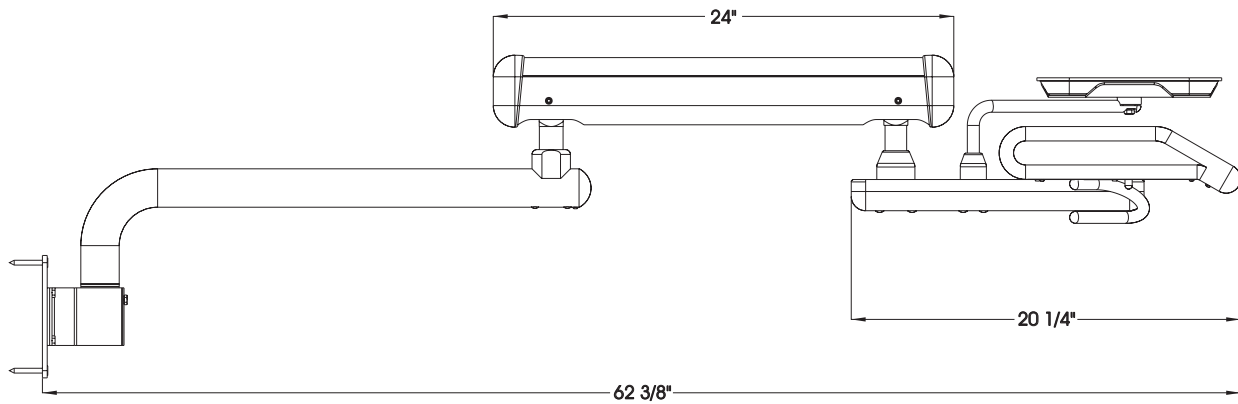
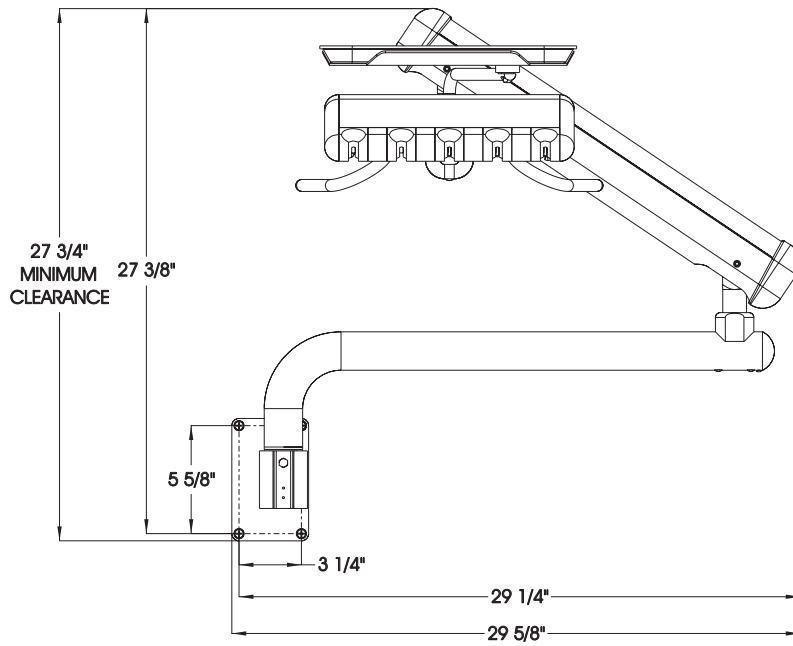

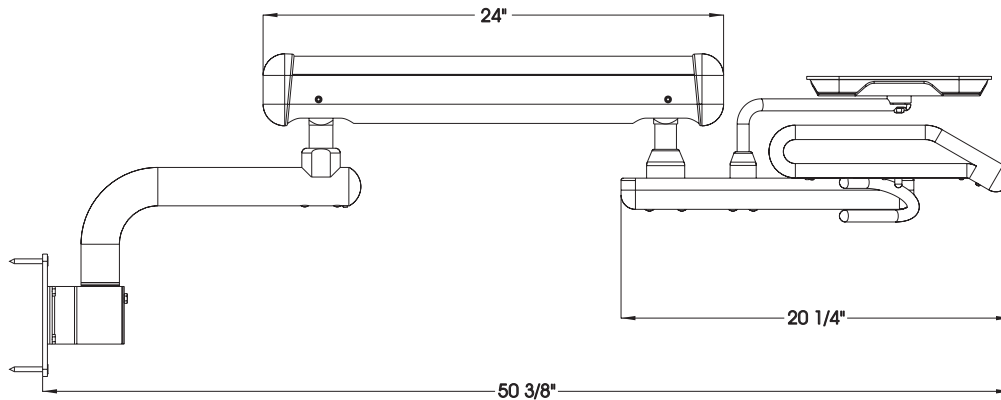
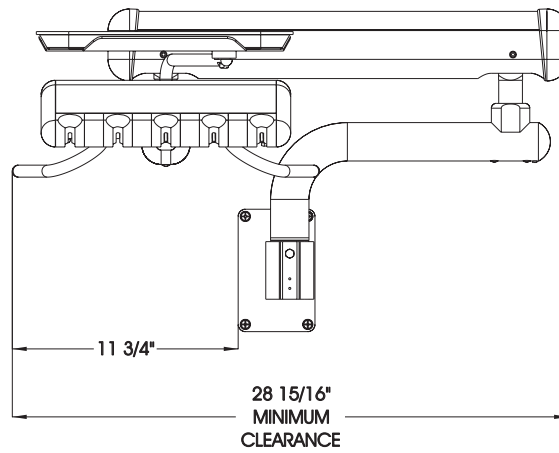
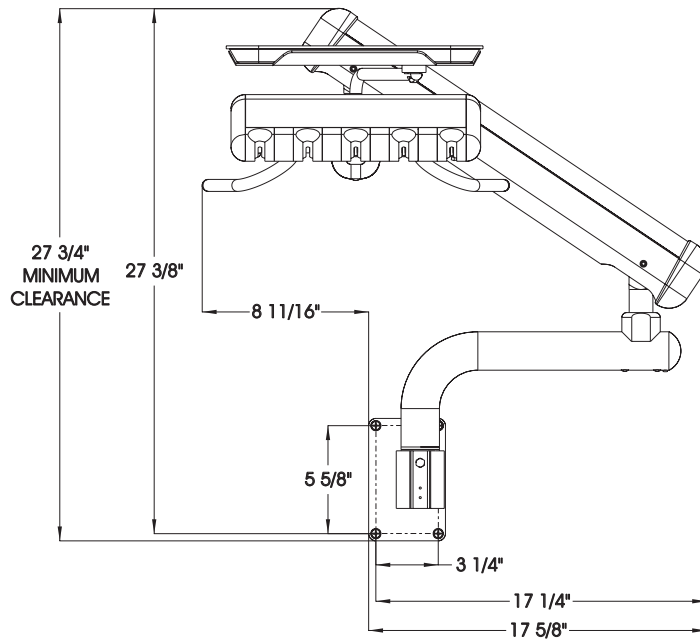

Installation for any of Engle's controls are simple. First you must install the Junction Box:

Junction Box:

Engle Dental Systems has simplified the connection of utilities within the Junction Box.

Templates for layout and elevation accompany this booklet (IL 017). Full size templates are available upon request when a layout is required.

1/2" N.P.T. threaded air and water supply pipes are brought 1" maximum above the finished floor. Supply Stop Valves are supplied for installation to the threaded supply pipes (see Figure 1).

Warning: After installation of the Supply Stop Valves to the threaded supply pipes, both of these Supply Stop Valves should be opened and flushed until the installer is certain that the supply lines and Supply Stop Valves are free of any debris prior to Air and Water Filter Regulator assembly installation.

The Air and Water Filter Regulator assemblies are pre-adjusted at the factory with the Water Regulator at 40 PSI and Air Regulator at 80 PSI. The nipple is inserted into the compression fitting of the Supply Stop Valve and tightened (see Figure 2).

Umbilical to Junction Box:

Determine the length required for the Umbilical, to the Junction Box. Cut to length as required and introduce the Umbilical into the desired hole of the Junction Box. Match the colors of the Umbilical tubes with the tubes that are connected to the Water and Air Regulators, then turn and lock the male and female Quick Disconnects together. Fittings are supplied also to connect the Vacuum and Drain lines.

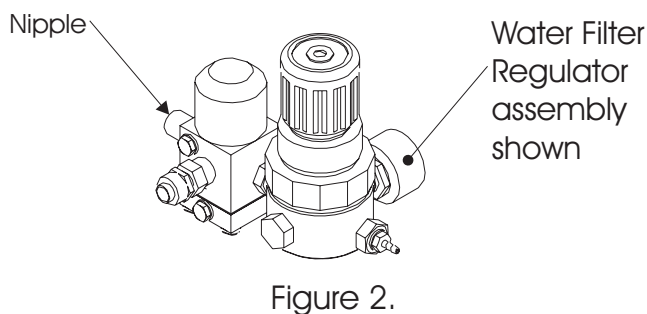
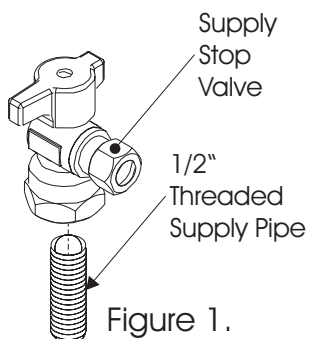

Small Junction Box Installation Diagram (34-000)

IL 017

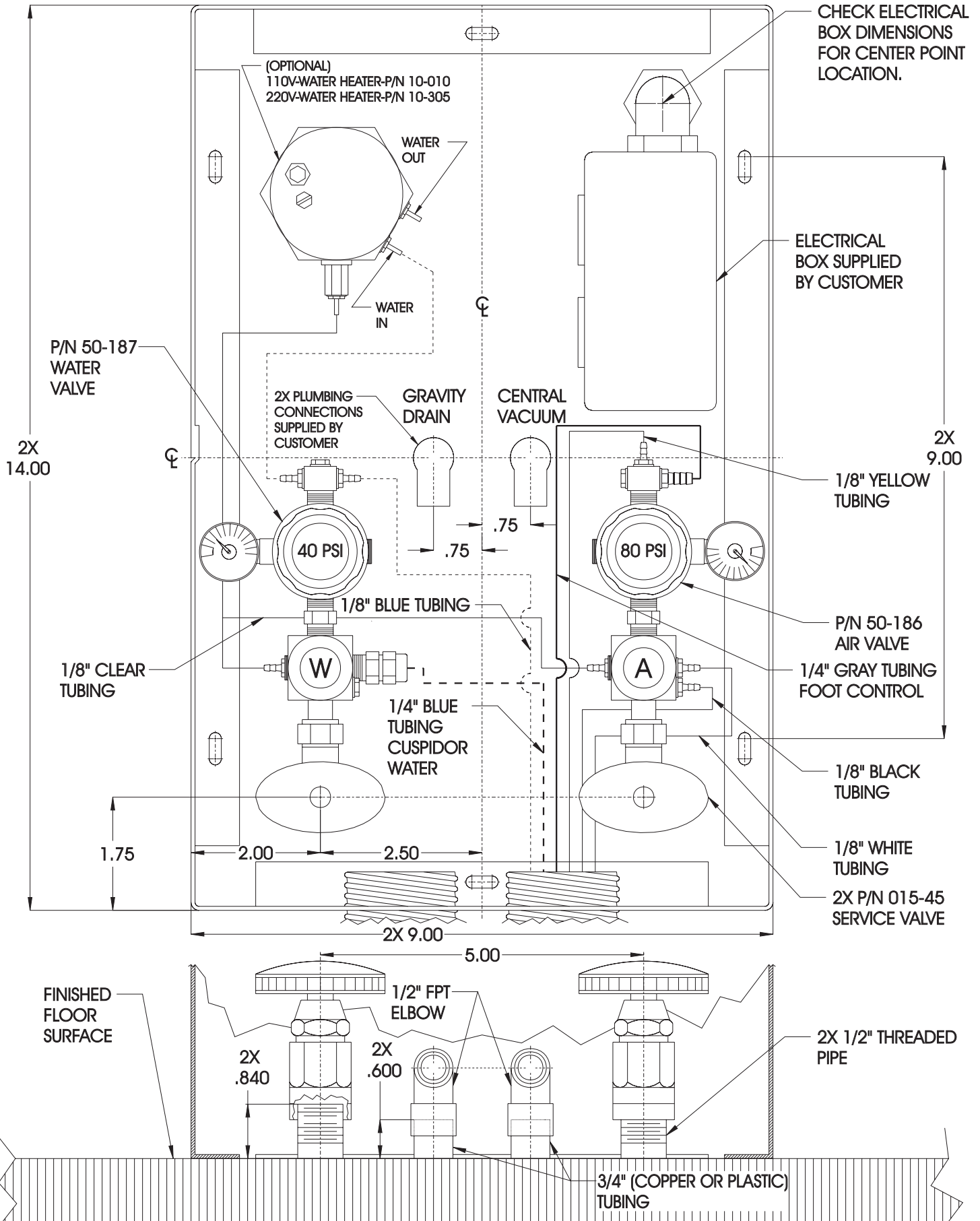

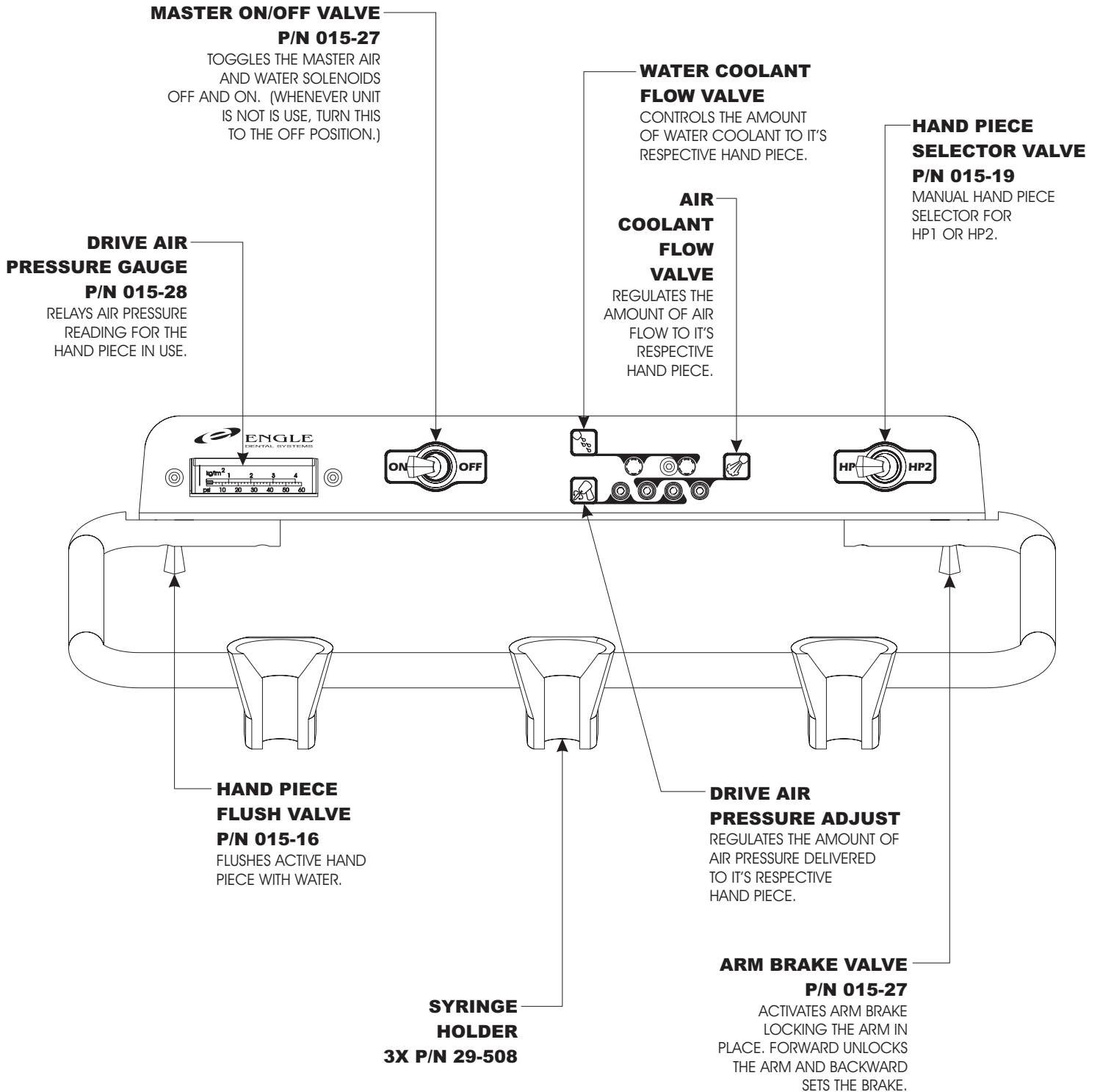

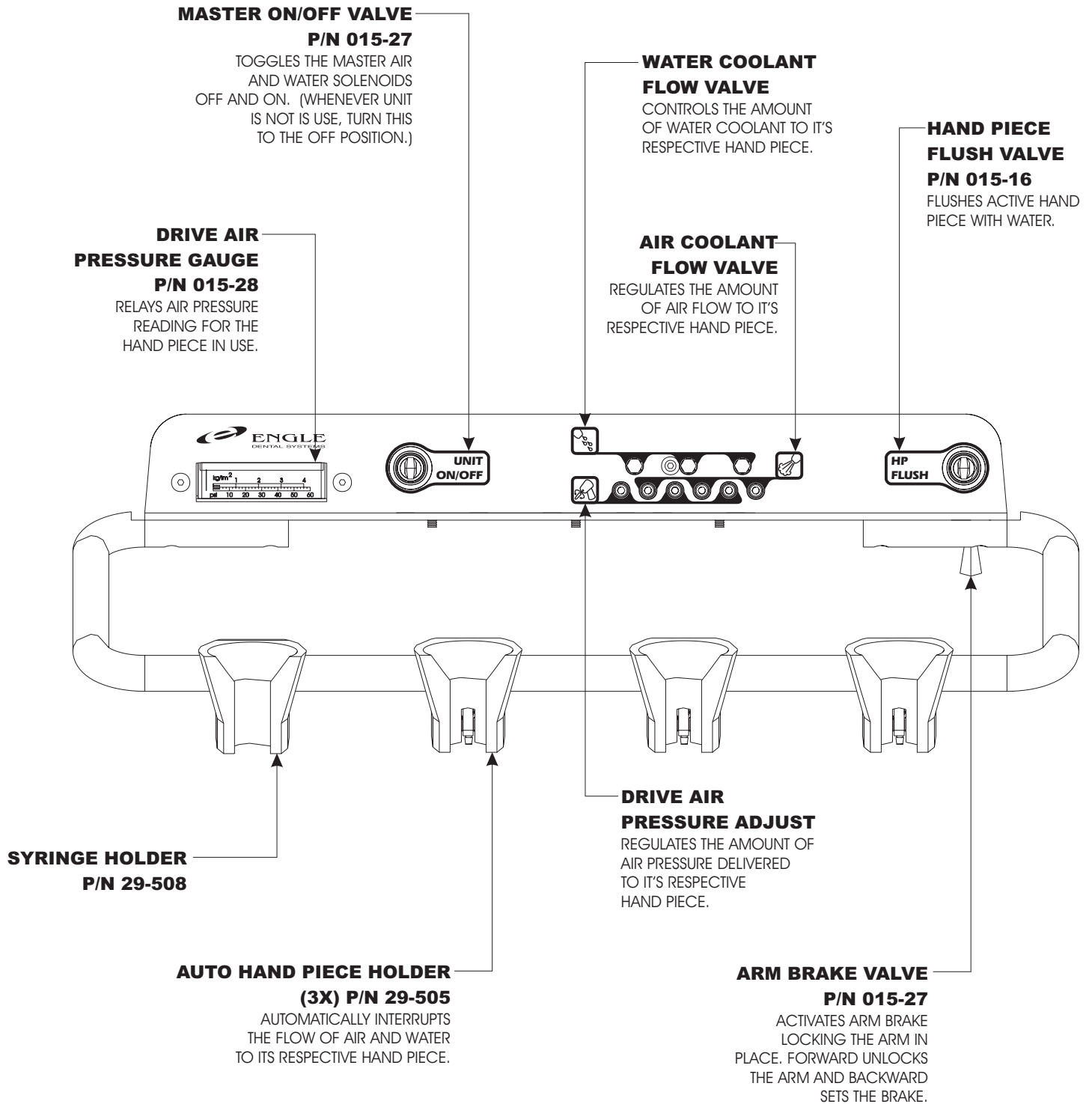

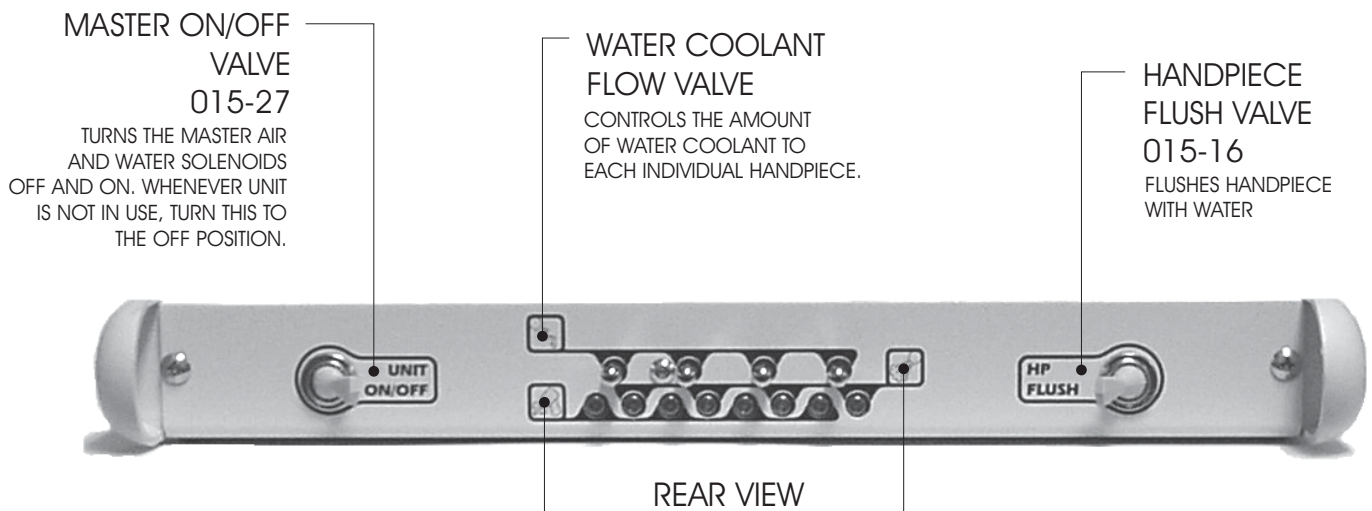
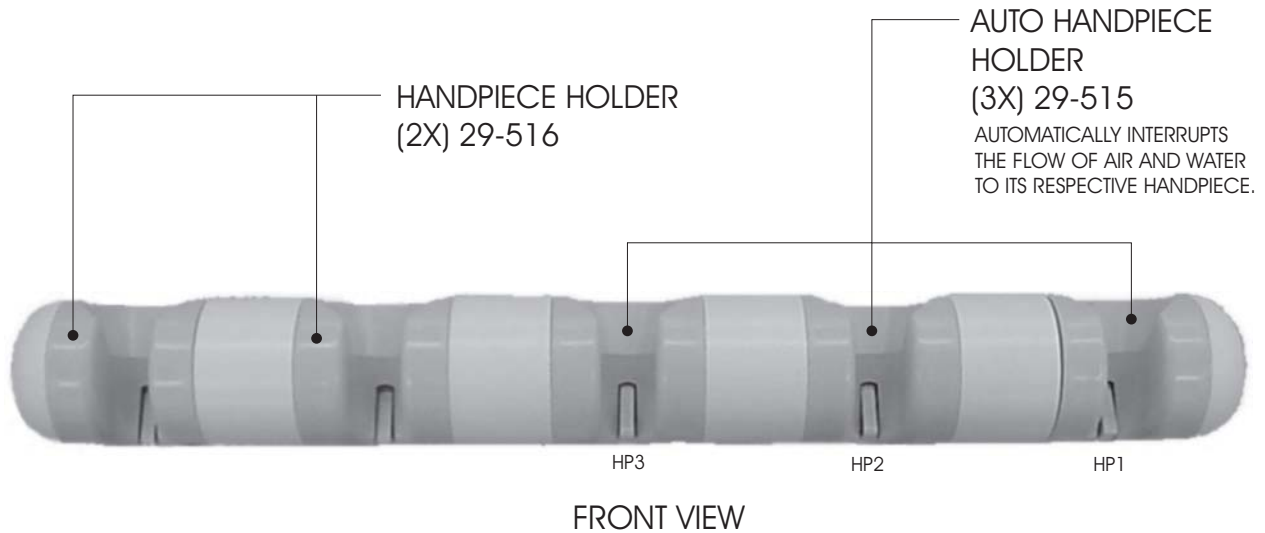

DRIVE AIR PRESSURE ADJUST
EACH SCREW ADJUSTS THE AMOUNT OF AIR PRESSURE DELIVERED TO EACH INDIVIDUAL HANDPIECE.

AIR COOLANT FLOW VALVE
REGULATES THE AMOUNT OF AIR COOLANT TO EACH INDIVIDUAL HANDPIECE.

DRIVE AIR PRESSURE GAUGE 015-85
GIVES AIR PRESSURE READING FOR THE HANDPIECE IN USE.

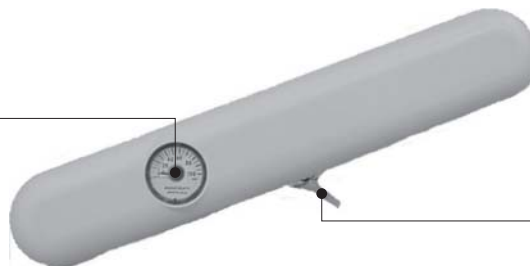

RIGHT SIDE VIEW

ARM BRAKE VALVE 015-27
ACTIVATES ARM BRAKE, LOCKING THE ARM IN PLACE. FORWARD UNLOCKS THE ARM AND BACKWARD SETS THE BRAKE.

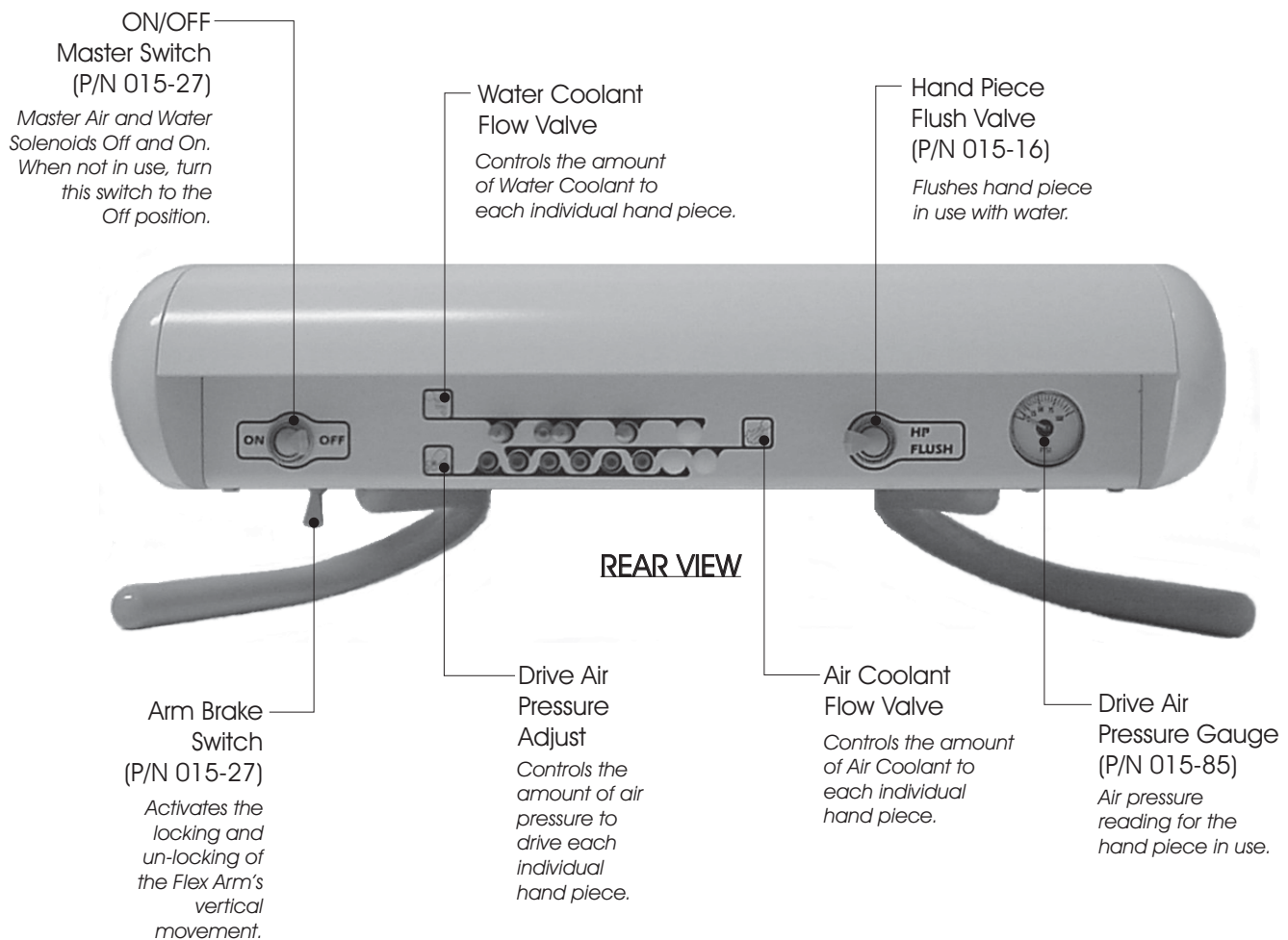
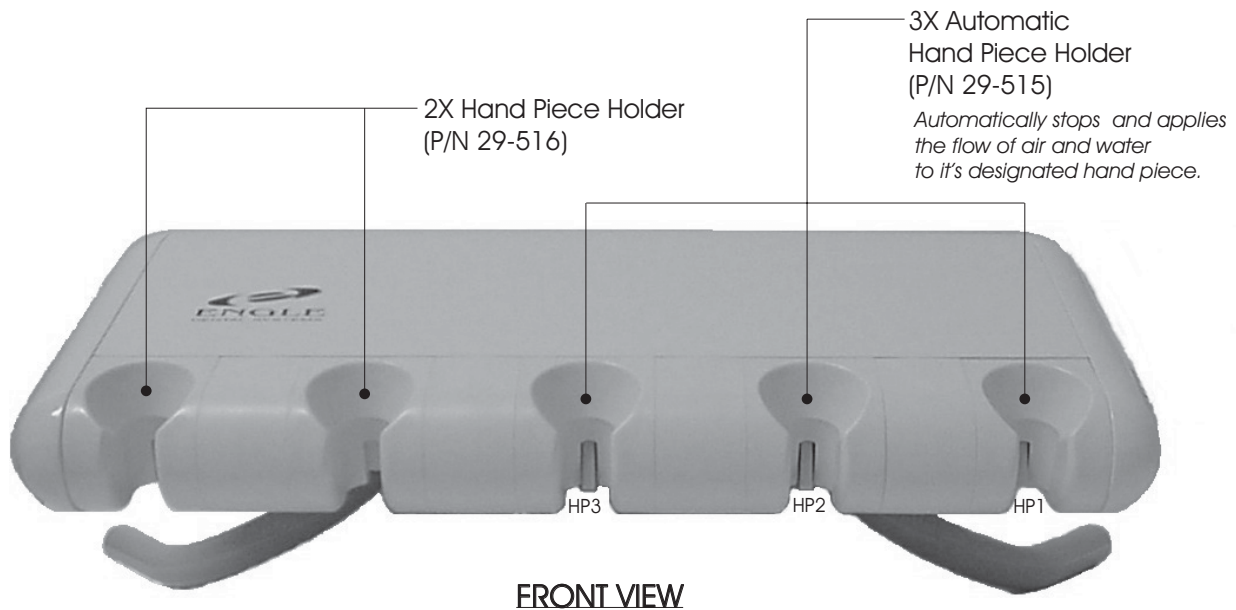

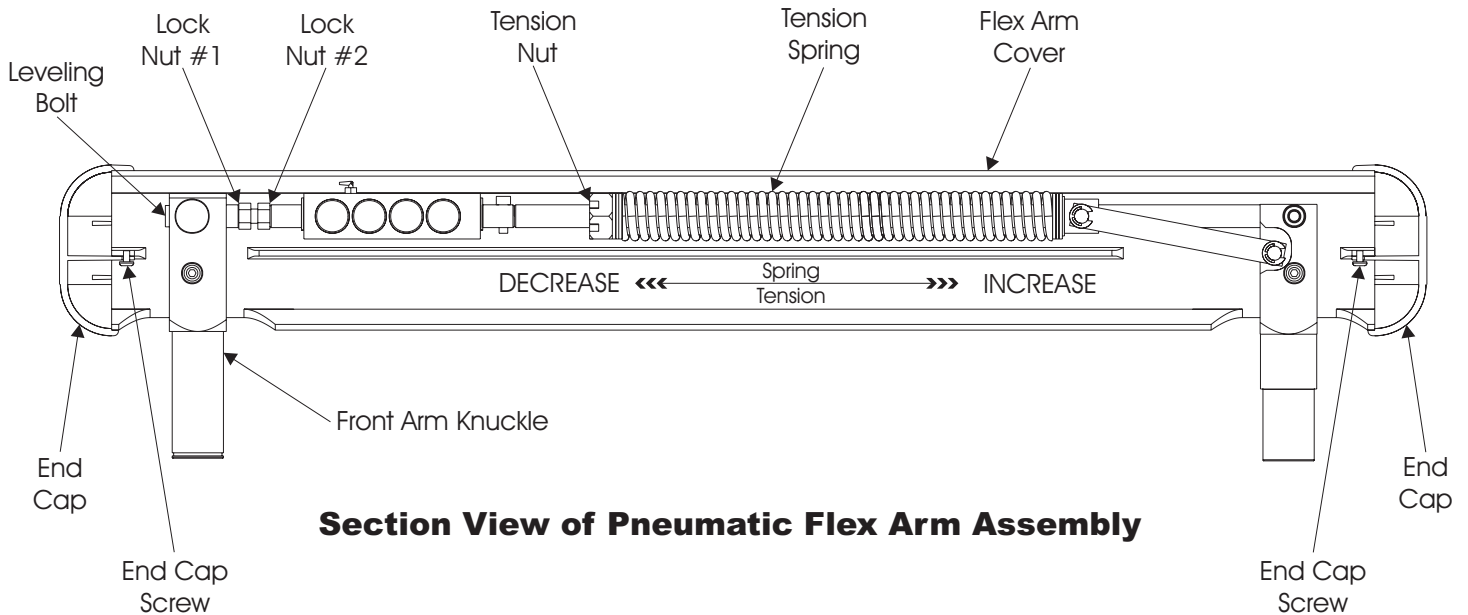

Spring Tension Adjustment:

1. Remove both End Caps, and Flex Arm Cover by un-installing the "two" End Cap Screws.
2. Use a 3/16" Allen wrench, insert it into a Slot of the Tension Nut and rotate it to increase or decrease tension on the Tension Spring. Looking from the Front Arm Knuckle side of the Flex Arm assembly, rotating the Tension Nut clockwise will increase tension and counter-clockwise will decrease tension.
3. With the complete service load of the Auto Control assembly, adjust the spring tension so that the Flex Arm will maintain all of the Auto Control's vertical positions when left unattended.
4. Re-install the Flex Arm Cover and both End Caps with the "two" End Cap Screws.

Front Arm Knuckle Pitch Adjustment:

1. Remove both End Caps, and Flex Arm Cover by un-installing the "two" End Cap Screws.
2. Loosen and back away Lock Nut #2.
3. Adjust the Leveling Bolt until the desired pitch of the Auto Control assembly is achieved.
4. Tighten Lock Nut #2 and check to make sure Lock Nut #1 is still tight, as shown.
5. Re-install the Flex Arm Cover and both End Caps with the "two" End Cap Screws.

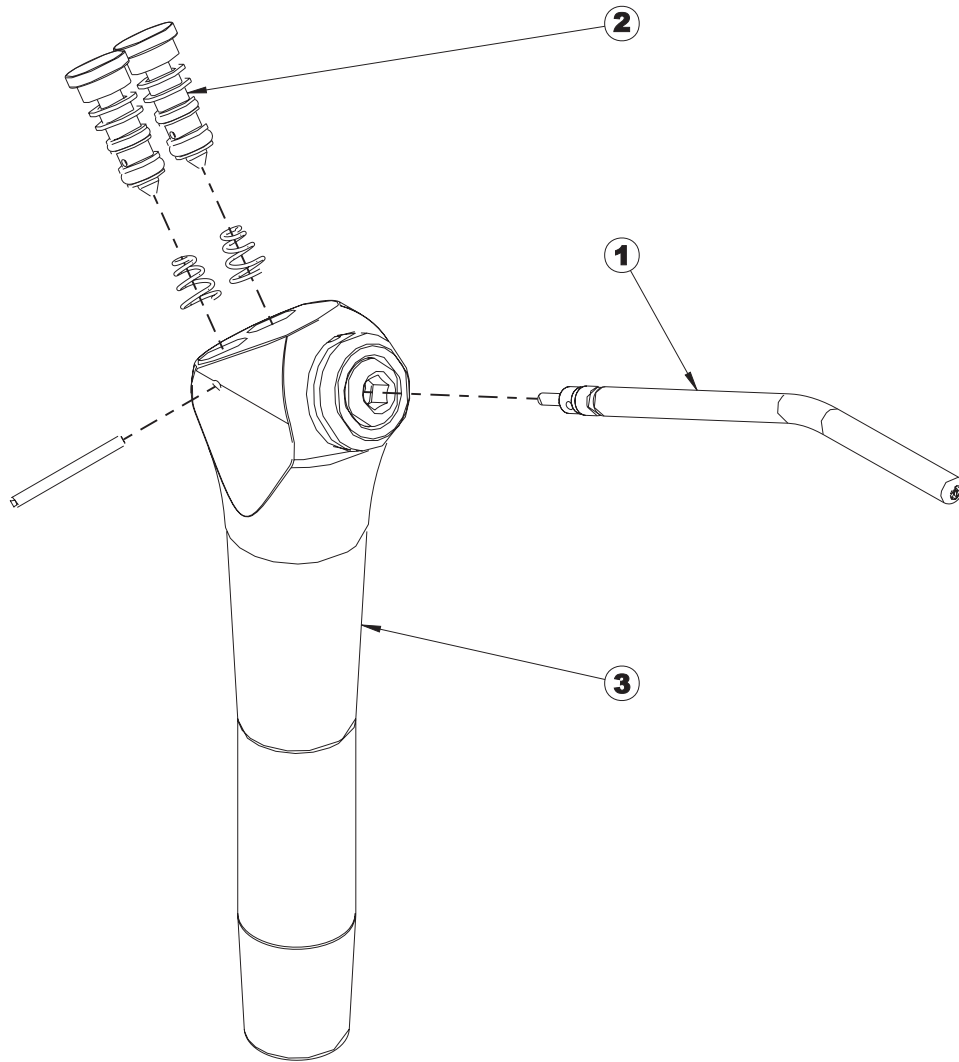

NO.	PART NO.	DESCRIPTION	QTY.
1	20-390	TIP	1
2	20-393	CARTRIDGE ASSEMBLY	2
3	20-395	SYRINGE	1

